

# 1600

## AIR DRYER

# BREEZE PRO

Our largest  
air dryer, ideal  
for Bulk Blast  
Machines.

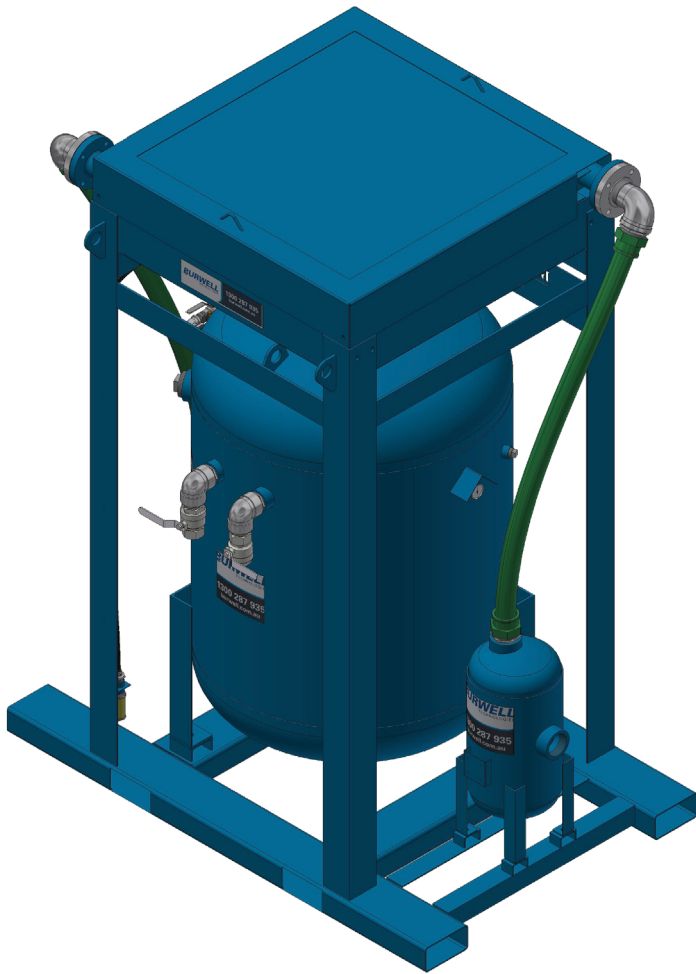

### DESICCANT-FREE

Desiccant-free design using Australian Made Coalescing Stainless Steel Filter.



### AUSTRALIAN MADE

Designed and made in Australia to AS1210 using Australian Plate Steel.



### BUILT TOUGH

Rated to 175 psi to meet all situations.



### QUIET

Designed to minimise operational sound levels.



### VERSATILE

Designed to withstand the harshest Australian climates and rugged terrains.



### PERFORMANCE

Removes up to 90% of moisture in blasting air.\*



### SITE READY

Forklift slots and lifting lugs remove the risk of unsafe manual handling.

#### Specifications

Airflow: 1600cfm @ 175psi
Filtration Type: 316ss Coalescing Filter
Weight: 550kg
Length: 1920mm
Width: 1400mm
Height: 2550mm
Outlet Size: 2 x 2" Ball Valve 1 x 3" Ball Valve

#### Inclusions

Pressure Relief Valve with Certificate
Air Regulator
Moisture Trap
Lubricator
2 x 2" Ball Valve
1 x 3" Ball Valve
Inline Water Separator
MDR & Australian Design Registration Certification

#### Part Number

#### Description

1404-1600	Burwell 1600 Breeze-Pro Air Dryer
-----------	-----------------------------------

Best Suited to Burwell MS3 & MS6 Bulk Blast Machines.

\*Conditions: Approx 35°C Ambient Temp, 100% Relative Humidity, Max Working Pressure: 200psi

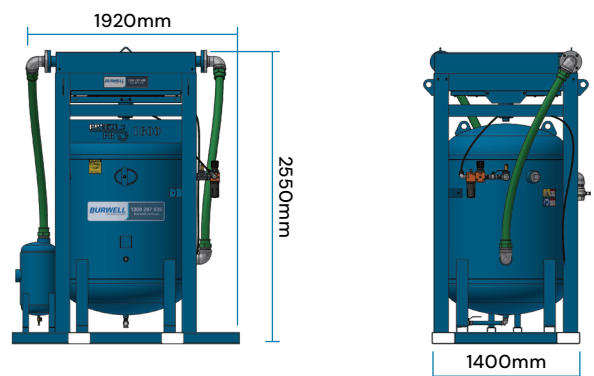

# BURWELL

1300 287 935 burwell.com.au

Version 241112