

1642

BLAST MACHINE

The "Portable Workhorse."

Approximately 60 minutes of blast time and designed to fit 6 x 25kg bags of garnet.

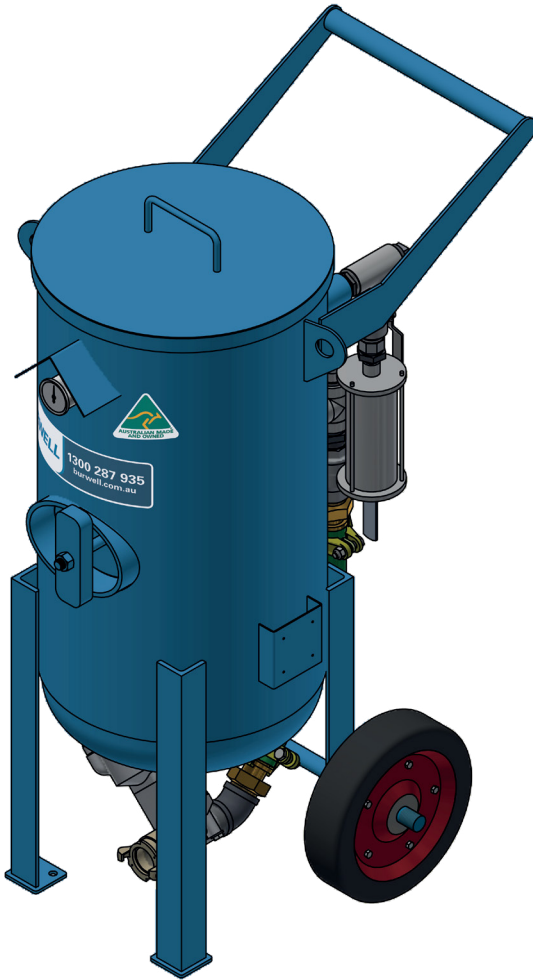

AUSTRALIAN MADE

Designed and made in Australia to AS1210 using Australian Plate Steel.



BUILT TOUGH

Rated to 175 psi (1205 kPa) to meet all situations.



STABLE

Four points of contact for maximum stability.



SAFE

Rated lifting lugs to make handling and transport safer and easier.



PERFORMANCE

Valving system designed to minimise pressure drop.



EASY TO LOAD

Low height of 1180mm makes it easier to load and handle.

Specifications

Useable Garnet Capacity: 175kg
 Vessel diameter: 405mm
 Weight: 145kg
 Length: 780mm
 Width: 580mm
 Height: 1180mm
 Volume: 90 litres (3.2 cu ft)

Inclusions

Screen & Lid
 1" Dump Valve & Silencer
 1-1/4" Micromiser Valve
 1-1/4" Auto Air Valve
 20m Deadman Control Line
 Pneumatic Deadman Trigger
 MDR & Australian Design
 Registration Certificate

Part Number

0191-1642-10

Description

Standard 1642 Blast Machine

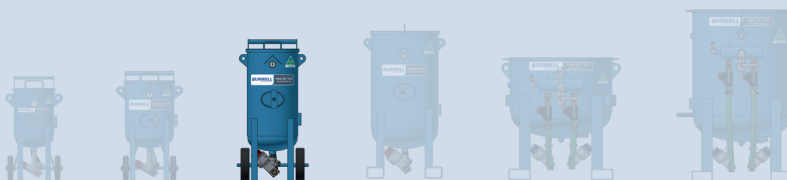
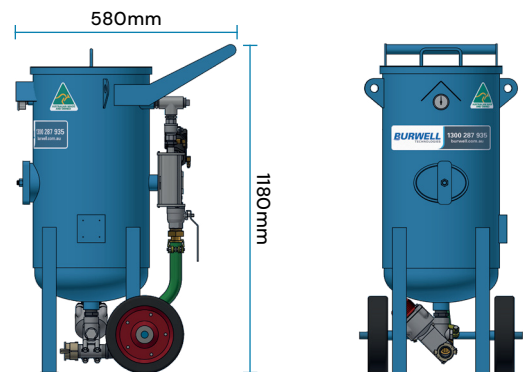

BURWELL

1300 287 935 burwell.com.au

Version 240602