

DUSTMASTER SERIES

MOBILE DUST COLLECTOR

ELITE MODEL
25,000 – 35,000 CFM

Ideal for large scale projects.

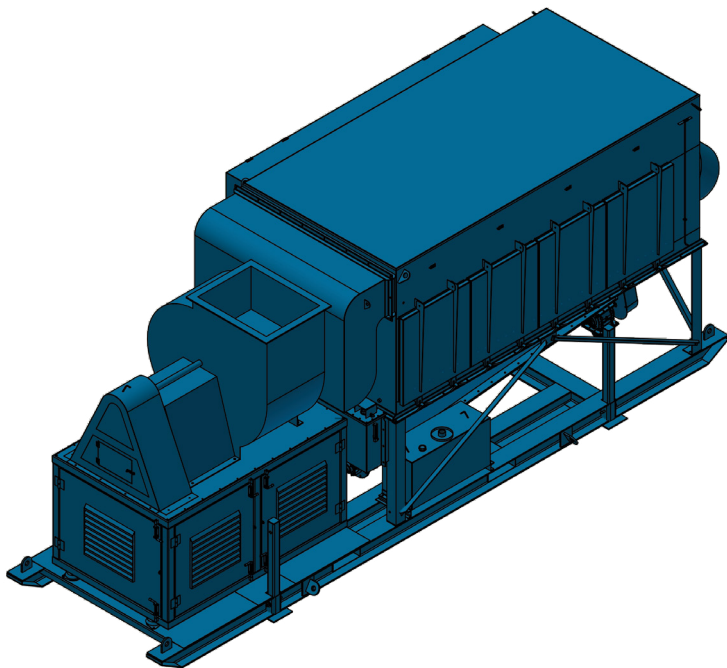

QUIET

Electric unit is designed to minimise operational sound levels.



REMOTE

Diesel unit is designed for remote work.



VERSATILE

Electric unit has the option of a genset to take it remote.



AUSTRALIAN MADE

Designed and made in Australia to AS1210 using Australian Plate Steel.



POWER MANAGEMENT

VSD starter on electric control board reduces power demand, reduces energy consumption and provides accurate airflow.



PERFORMANCE

Designed for long duct runs.



SITE READY

Forklift slots and lifting lugs remove the risk of unsafe manual handling.



COMPACT DESIGN

Small footprint for site mobilisation.

Specifications

Weight: 9000kg
Length: 7880mm
Width: 2340mm
Height: 3200mm

Options

Genset 104 kva
Diesel
Auger - 150mm diameter screw

Inclusions

Electrical: 415 volts, 3 phase, 50 HZ power requirement for VSD control panel
Plug: 63 amp plug with 10m lead
Fan: Rated for high static resistance to allow for duct runs up to 250m
Silenced pulse valve enclosure 84 dBA
Gold cone cartridge filters
Automated pulse control system
Telescopic legs for hopper discharge

Part Number

Description

MDC-ELITE-E	Dustmaster Elite Mobile Dust Collector - Electric
MDC-ELITE-D	Dustmaster Elite Mobile Dust Collector - Diesel
MDC-GEN-ELITE	Genset for electric dust collector (ELITE) 104 kva
MDC-AUGER-ELITE	Auger 150mm diameter screw with rotary lock

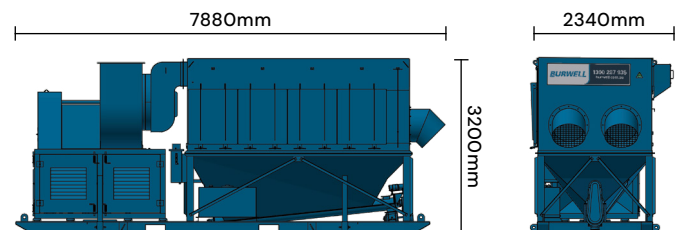

BURWELL

1300 287 935 burwell.com.au

Version 241120