

DUSTMASTER SERIES

MOBILE DUST COLLECTOR

PRO MODEL
15,000 – 20,000 CFM

Ideal for large scale projects.

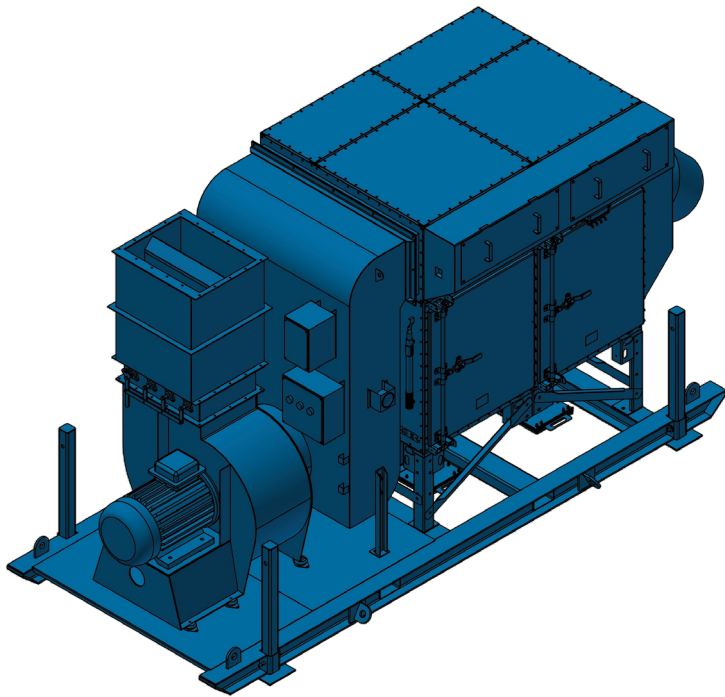

QUIET

Electric unit is designed to minimise operational sound levels.



REMOTE

Diesel unit is designed for remote work.



VERSATILE

Electric unit has the option of a genset to take it remote.



AUSTRALIAN MADE

Designed and made in Australia to AS1210 using Australian Plate Steel.



POWER MANAGEMENT

VSD starter on electric control board reduces power demand, reduces energy consumption and provides accurate airflow.



PERFORMANCE

Designed for long duct runs.



SITE READY

Forklift slots and lifting lugs remove the risk of unsafe manual handling.



COMPACT DESIGN

Small footprint for site mobilisation.

Specifications

Weight: 4500kg
Length: 5350mm
Width: 2250mm
Height: 2770mm

Options

Genset 60 kva
Diesel
Auger - 150mm diameter screw

Inclusions

Electrical: 415 volts, 3 phase, 50 HZ power requirement for VSD control panel
Plug: 50 amp plug with 10m lead
Fan: Rated for high static resistance to allow for duct runs up to 250m
Silenced pulse valve enclosure 84 dBA
Gold cone cartridge filters
Automated pulse control system
Telescopic legs for hopper discharge

Part Number

Description

MDC-PRO-E	Dustmaster Pro Mobile Dust Collector – Electric
MDC-PRO-D	Dustmaster Pro Mobile Dust Collector – Diesel
MDC-GEN-PRO	Genset for electric dust collector (PRO) 60kva
MDC-AUGER-PRO	Auger 150mm diameter screw with rotary lock

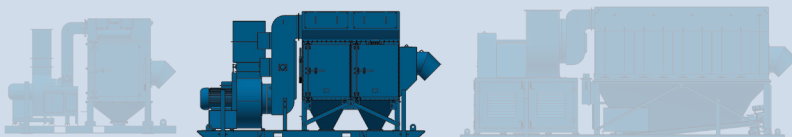
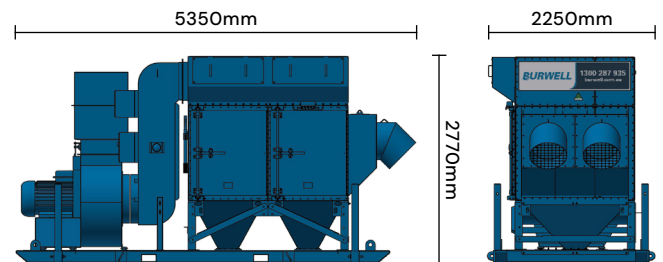

BURWELL

1300 287 935 burwell.com.au

Version 241120