

LOAD HOPPER

Effective and Secure

A convenient way to load your Blast Machine.

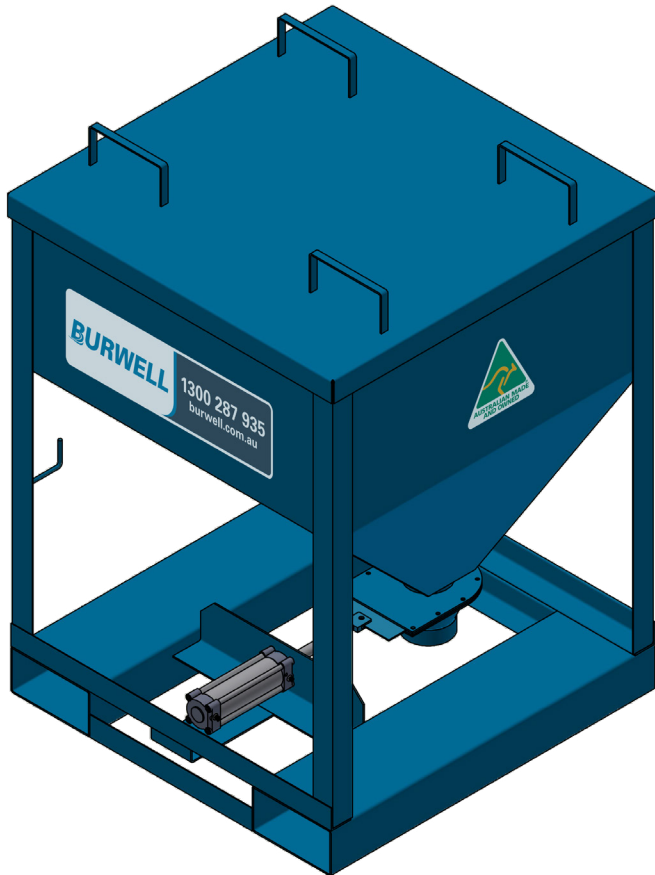

BUILT TOUGH

Engineer certified for rating up to 3 tonne loads.



MANEUVERABILITY

Toggle switch operated from ground level and all equipment have tyne slots.



AUSTRALIAN MADE

Designed and made in Australia to AS4100 using Australian Steel.



SITE READY

Forklift slots comply with Australian safety and site standards.



SCREENING

Internal mesh screen to prevent foreign material entering the blasting vessel.

Specifications

2 tonne Garnet Capacity Hopper
Pneumatic knife gate with pneumatic cylinder
Length: 1250mm
Width: 1250mm
Height: 1750mm

Inclusions

Pneumatic operated toggle switch

Part Number

1304-1202

Description

Burwell Load Hopper



The convenient way to refill your Blast Machine.

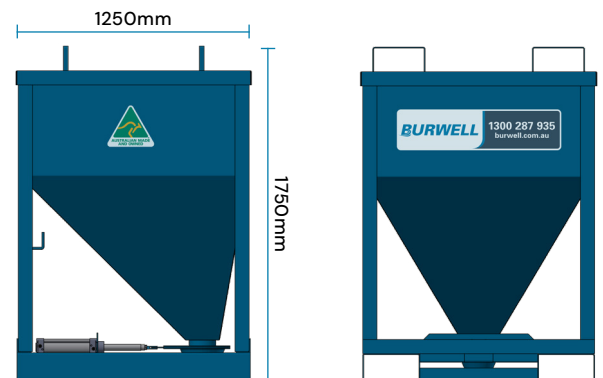

BURWELL

1300 287 935 burwell.com.au

Version 240727