

SAFETY LOAD SYSTEM

Protecting Workers

A safe way to load your Blast Machines from Bulker Bags.

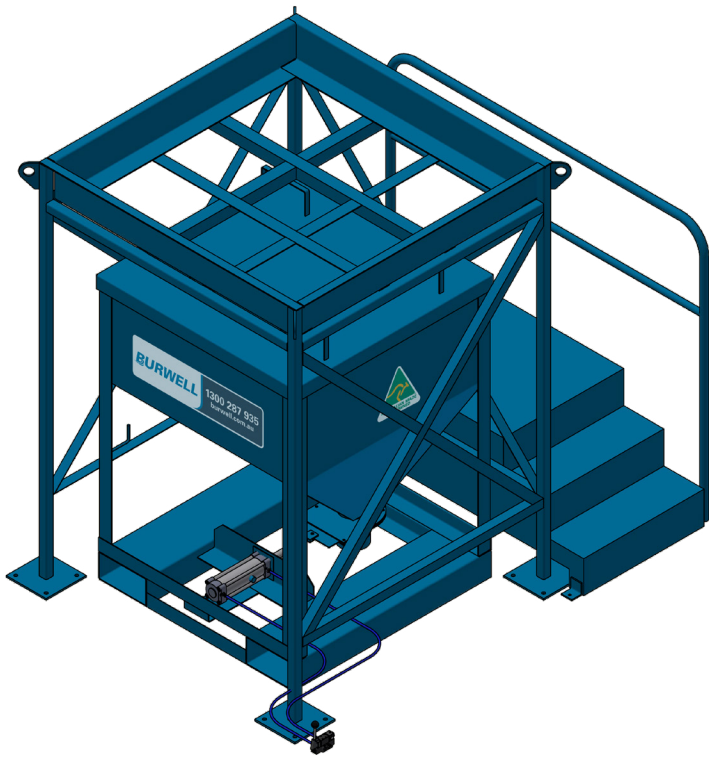

SAFETY

Removes working at heights risks and working under suspended loads.



BUILT TOUGH

Engineer certified for rating up to 3 tonne loads.



FUNCTIONALITY

Toggle switch operated from ground level and all equipment have tyne slots.



AUSTRALIAN MADE

Designed and made in Australia to AS4100 using Australian Steel.



AWARDED

Site award for safety practices.



SITE READY

Forklift slots comply with Australian safety and site standards.



SCREENING

Internal mesh screen to prevent foreign material entering the blasting vessel.

Specifications

2 tonne Garnet Capacity Hopper
Pneumatic knife gate with pneumatic cylinder
Length: 2650mm
Width: 2000mm
Height: 2250mm

Inclusions

Pneumatic operated toggle switch

Part Number

0304-1205

Description

Burwell Safety Load System

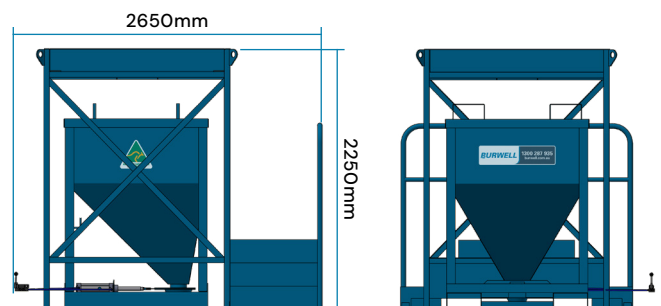

STEPS

1. Empty bulker bag into hopper
2. Position hopper above Blast Machine
3. Use toggle switch to release abrasive
4. You're ready to blast!

BURWELL

1300 287 935 burwell.com.au

Version 240727