

## Container Blast Room

### Specifications

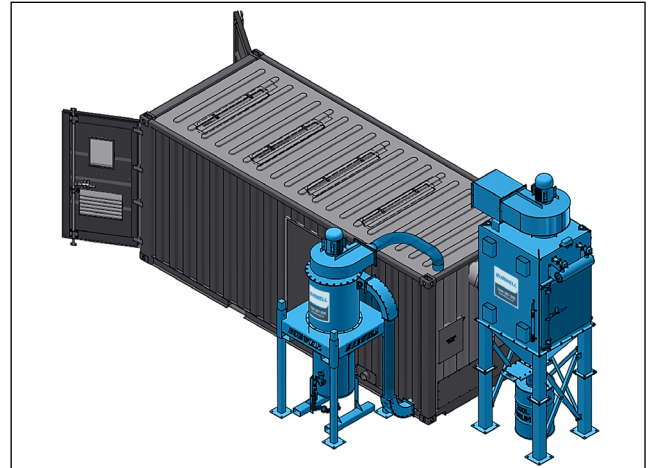

<b>Dust Collector</b>	Vertical filter – Burwell 5000 CFM, 7.5kW motor 4 Cartridge
<b>Personnel Door</b>	Included
<b>Abrasive Recovery Method</b>	Full Width Pneumatic Abrasive Recovery with Rubber-Lined Cyclone (VSD controlled) 5.5kW
<b>Abrasive Elbow</b>	Smooth highly wear-resistant
<b>Blast Machine</b>	2449 (400kg Garnet Capacity)
<b>Blast Room Lighting</b>	6 off
<b>Electrical</b>	415V, 3-phase, N & E 32 Amp plug Plug and Play



### SUBCOMPONENTS OF A BLAST ROOM:

1. Container Blast Room
2. Recovery and Recycling System
3. Dust Collector
4. Mechanical Services (Electrical & Air)

CONTAINER BLAST ROOM	
FEATURES	BENEFITS
Can utilize all container types: 20ft, 40ft, Hi Cube and Side opening	Adoptable to suit material handling processes and customer equipment
All components can be transported inside of container	Mobile System – can be used from site to site
5mm steel plate floor	Wear resistant
Man door included	Safety compliant
Rubber blankets on internal walls	Reduced noise and wear property
Container Access Ramp	Forklift access

RECOVERY AND RECYCLING SYSTEM	
FEATURES	BENEFITS
Feed ramp conveyor	No requirement to raise container
Drop down legs	Easy to assemble and freight Adjustable to suit blast machine height
5.5 kW motor with VSD. Includes knob control for speed adjustment	Suitable for all abrasives and able to adapt to new load demands
2T per hour capacity	High productivity recycling system

DUST COLLECTOR	
FEATURES	BENEFITS
Deflector plate built internal of top half	Standardise duct entering the dust collector
Cam Lock filter door handles	Easy to maintain
Vertically stacked dust cartridge filters	Superior cleaning
Noise attenuation box for pulse valves	Reduces pulsing from 92 DbA to 86 DbA
Utilise Gold Cone cartridges	Reduced footprint

MECHANICAL SERVICES (ELECTRICAL & AIR)	
FEATURES	BENEFITS
Individual control panel for recycling system and dust collector 32 Amp plug with 10m lead	Plug and play Cables will be sent coiled up with connectors All motors will be already hard-wired
IP66 enclosure	Protected from dust and moisture
Pre plumbed lines for air	Plug and play
Lights – 1000 Lux from 1 meter above ground level	High visibility during dust clouds